

# **Promate**<sup>®</sup>

## **Operator Manual**

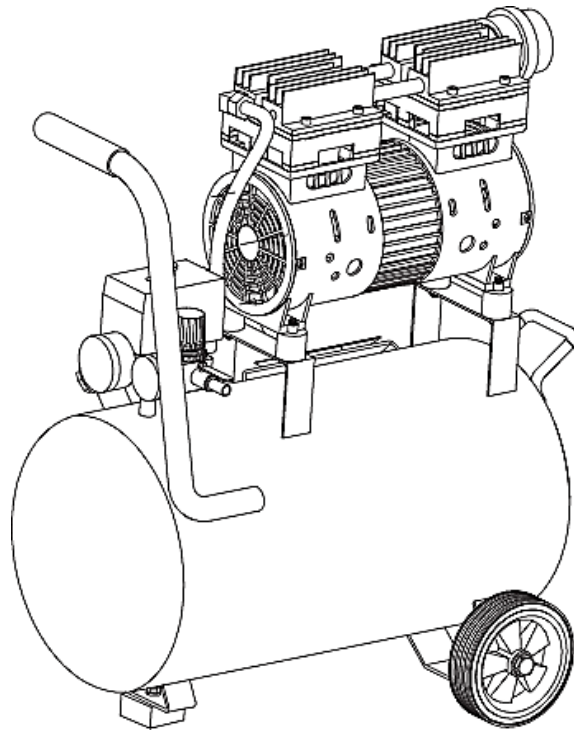

### **AIR COMPRESSOR**

**IMPORTANT** – Please make certain that persons who are to use this equipment thoroughly read and understand these instructions and any additional instructions provided prior to operation.

Record the model and serial numbers of your Generator below:

Model No. \_\_\_\_\_ Serial No. \_\_\_\_\_

## FOREWORD

Thank you for purchasing our product. This operator manual is for proper handling, minor checking and maintenance of the air compressor. Before using your air compressor: Please read these instructions completely and carefully in order to make the best use of it as well as operate it safely. Due to constant efforts to improve our products, certain procedures and specifications are subject to change without notice, if you have any questions, please contact Promate Service.









## CONTENTS

1	Safety Precautions	3
2	Key Parts Diagram	4
	2-1 Parts Description	4
	2-2 Pre-Operation Checklist	5
3	Assembly	5
	3-1 Preparation	5
	3-2 Assembly Instructions	5
	3-3 Pre-Starting Instructions	5
	3-4 Test Run	5
4	Operation	6
	4-1 Before Starting	6
	4-2 Starting the Compressor	6
	4-3 Shutting down the compressor	6
5	Maintenance and Storage	7
6	Troubleshooting	8
7	Service Information	9
	Air Compressor Exploded View	10

# 1. Safety Precautions

When handling this unit, please keep to the following matters. Please make sure you review each precaution carefully. You must also make sure that the procedure, work method, or operating technique that you choose does not render the compressor unsafe.

## Safety Symbols and Meanings

	<b>Operator's Manual</b>	Do not operate this air compressor until you read and understand this operator manual for safety, operation, and maintenance instructions.
	<b>Risk of Fire</b>	Risk of fire could result in death or serious injury: <ul style="list-style-type: none"> <li>- Do not spray flammable material in vicinity of any flame or ignition sources including the compressor unit.</li> <li>- Do not restrict compressor ventilation openings or place objects against or on top of compressor. Operate in a clean, dry, and well-ventilated area only.</li> <li>- Do not operate unattended. Always turn off and unplug the unit when not in use.</li> </ul>
	<b>Bursting</b>	Never operate above maximum operating pressure of the spray gun or tool. Drain water from the tank after each use. <ul style="list-style-type: none"> <li>- Do not weld or repair tank.</li> <li>- Do no operate with pressure switch or safety valve set above maximum allowable working pressure.</li> </ul>
	<b>Hot Surface</b>	Hot compressor surfaces could result in serious injury. Allow compressor to cool before touching.
	<b>Toxic Fumes</b>	Inhalation hazard. Using compressor to supply for breathing air could result in death or serious injury.
	<b>Flying Objects</b>	Risk of serious eye injury. Always wear ANSI 287.1 approved safety glasses when using the air compressor. Do not spray at any part of the body.
	<b>Hearing</b>	Always wear hearing protection when using the air compressor.
	<b>Electric Shock</b>	Connect the air compressor to a properly grounded receptacle only. KEEP CHILDREN AWAY FROM THE AIR COMPRESSOR AT ALL TIMES.

## 2. Key Parts Diagram

Read this owner's manual before operating your air compressor. Familiarize yourself with the location and function of the controls and features. Save this manual for future reference.

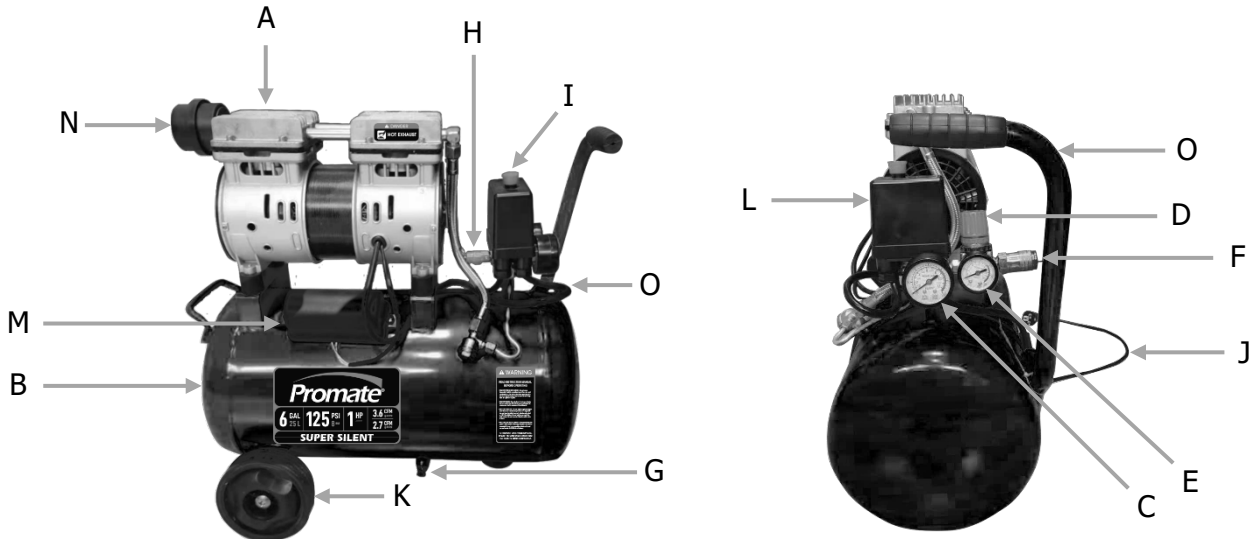

- A. Pump/Motor Assembly
- B. Air Tank
- C. Tank Pressure Gauge
- D. Air Pressure Regulator
- E. Regulated Pressure Gauge
- F. Quick Connect Outlet
- G. Tank Drain Valve
- H. Pressure Relief Valve

- I. ON/OFF Button
- J. Power Cord
- K. Wheel
- L. Pressure Switch
- M. Capacitor
- N. Air Filter
- O. Handle

### 2-1 Parts Description

- A. PUMP/MOTOR ASSEMBLY:** The electric motor is used to power the pump. It contains a thermal overload protector. If the motor overheats for any reason, the thermal overload protector will shut it down in order to prevent the motor from being damaged.  
**AIR COMPRESSOR PUMP:** The pump is used to compress the air and discharge it into the tank via the piston moving up and down the cylinder.
- B. AIR TANK:** The tank is used to store the compressed air.
- C. TANK PRESSURE GAUGE:** The gauge is used to measure the stored air pressure level of the tank. It is not adjustable by the operator and does not indicate line pressure.
- D. AIR PRESSURE REGULATOR:** The regulator is used to adjust the line pressure to the tool you are using. Turn the knob clockwise to increase pressure and counterclockwise to decrease pressure.

#### WARNING



Never exceed the maximum working pressure of the tool.

- E. REGULATED PRESSURE GAUGE:** The gauge is used to measure the regulated outlet pressure.
- F. QUICK CONNECT OUTLET:** The outlet is used to connect the air hose with quick connector.
- G. AIR TANK DRAIN VALVE:** The drain valve is used to remove moisture from the air tank after the unit is shut off.

#### WARNING



Never attempt to open the drain valve when the tank pressure is more than 10 PSI

- H. PRESSURE RELIEF VALVE:** If the pressure reaches the preset level motor, it will automatically pop open. You can also pull the ring on the valve to open.
- I. ON/OFF SWITCH:** This switch turns ON the compressor and is operated manually. ALWAYS set the switch OFF when the compressor is not being used and before unplugging the compressor.
- J. POWER CORD:** The product is for use on a nominal 220V circuit and should be grounded. A cord with a grounding plug as illustrated must be used. Make sure that the product is connected to an outlet that has the same configuration as the plug (see Fig. 1). Do not use an adapter.

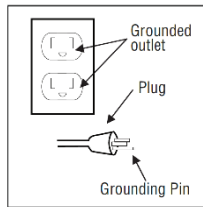

Fig. 1

**⚠ DANGER**



If repair or replacement of the cord or plug is necessary, do not connect the grounding wire to either flat blade terminal. The grounding wire is in the green outer surface.

## 2-2 Pre-operation Checklist

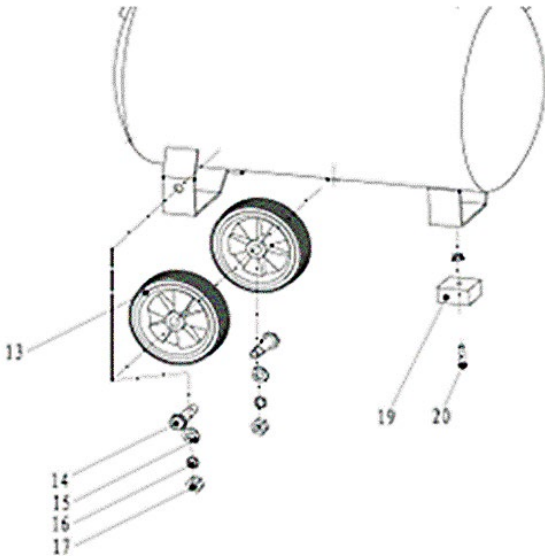

Package Contents		
Item No.	Qty	Item
	1	Air Compressor
	1	Owner's Manual
	1	Air Filter
13	2	Wheel
14	2	Bolt
15	2	Flat Washer
16	2	Spring Washer
17	2	Nut
19	1	Shock Strut
20	1	Bolt

## 3. Assembly

### 3-1 Preparation

Before beginning assembly of product, make sure all parts are present. Compare parts with package contents list and hardware contents list. If any part is missing or damaged, do not attempt to assemble the product.

**Estimated Assembly Time:** 5 minutes

### 3-2 Assembly Instructions

#### Install the Air Filter

1. Screw the Air Filter (N) on the top rear of the motor/pump head (As shown in key part diagram, pg. 2)

#### Install the Wheel Kit

1. Slide Flat Washer #15 to Bolt #14.
2. Slide Bolt #14 through the Wheel #13.  
Slide the Bolt and Wheel through the wheel support hole located on the back bottom of the air compressor tank.
3. Attach the Spring Washer #16 and Nut #17 to the Bolt #14 and tighten firmly.
4. Repeat steps 1-3 to assemble the other wheel.
5. Slide the Bolt #20 through the washer and Cushion Foot #19.

6. Slide Bolt #17 through the cushion foot support hole located on the front bottom of the air compressor.

### 3-3 Pre-Starting Instructions

1. Connect your air supply hose to a quick connect coupler. Connect the male quick connect coupler to the female quick connect coupler located on the air compressor.
2. Make sure the tank drainage valve (**G**) is in the closed position and that the pressure switch is in the OFF position.
3. Ensure that the power supply you are going to use is operating normally.
4. Insert the power supply cord into the power supply socket.

### 3-4 Test Run

Before using the air compressor for the first time, complete a test run as follows:

1. Push the power switch to the OFF position. Plug the power supply cord into a power supply socket. Start the air compressor by pulling the power switch to the ON position. The pressure gauge reading will slowly rise as pressure increases inside the air tank. When the gauge

reading reaches 125 PSI, the pressure switch will automatically turn the power OFF. This indicates the compressor is working normally.

2. Turn the power switch to the OFF position, unplug the power supply cord and release the air in the tank by pulling on the safety valve. At this point, proceed to the next step (Daily Operation).

### NOTE

If the Air Compressor is not working properly, the pressure gauge will indicate that there is a decrease in pressure in the air tank. If there is an air leak from the compressor, the pressure in the air tank decreases, then the pressure switch resets and the motor automatically turns back ON.

If you detect an air leakage, push the power switch to the OFF position, release the air from the tank by pulling on the safety valve.

## 4. Operation

### 4-1 Before Starting

1. Push the Engine Switch to the OFF position.
2. Turn the air pressure regulator knob (D) counterclockwise until it stops.
3. Attach the air hose/accessories or air tools (not included) to the air line outlet (F).

#### WARNING



Check the manufacturer's maximum pressure rating for air tools and accessories. The regulator outlet

pressure must never exceed the maximum pressure rating.

### 4-2 Starting the compressor

1. Close the air tank drain valve (G) by turning it counter clockwise (left to right).
2. Plug the power cord (J)
3. Pull the Engine Switch to the ON position and allow tank pressure to build. The motor will stop when the tank pressure reaches "cut-out" pressure.
4. Turn the air pressure regulator (D) clockwise until desired pressure is reached.
5. The compressor is ready for use.

### 4-3 Shutting down the compressor

1. Push the Engine Switch to the OFF position.
2. Unplug the power cord.
3. Reduce the pressure in the air tank through the air supply hose or from the drain valve. Pulling the pressure valve ring (H) and keeping it open will also reduce the pressure in the tank.
4. Tip the compressor so the tank drain valve is at the bottom of the tank, then open the tank drain valve clockwise (right to left) to allow moisture to drain from the tank.

#### CAUTION



Wear safety glasses when opening the drain valve

#### WARNING



Always shut off and unplug the unit and relieve pressure from the system before performing any service on the unit.



Before performing any maintenance or repair, disconnect power source from the compressor and bleed of all air pressure.

## 5. Maintenance and Storage

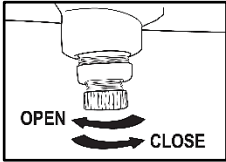
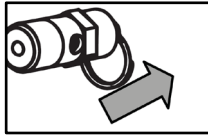
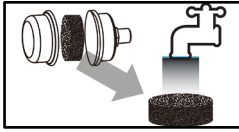
Task	Description	Service Internal
Drain the tank	<p>To prevent corrosion inside the tank, the condensation must be drained at the end of every workday. Be sure to wear protective goggles. Relieve the air pressure in the system and then open the drain valve on the bottom of the tank.</p> 	Daily
Check the relief valve	<p>Pull the relief valve on the ring daily to ensure that it is operating properly and to clear the valve of any possible obstructions.</p> 	Daily
Clean the air filter	<p>To avoid any contamination inside the pump, the filter should be cleaned frequently and replaced on a regular basis. Foam filter should be cleaned in warm and soapy water.</p> 	Weekly
Test for leakage	<p>Check all connections to see if tight. A small leak of any part (the tank, hoses, pipe connections or transfer tubes) will reduce</p>	Monthly
Storage	<p>Before storing the unit for a long period, use an air blow gun to clean all the dust and debris from the compressor. Disconnect and coil the power cord. Pull the pressure relief valve to release all pressure from the tank. Drain all moisture from the tank. Cover the entire unit to protect it from moisture and dust.</p>	Before prolonged storage

### WARNING



Always shut off and unplug the unit and relieve all air pressure from the system before performing.

## 6. Troubleshooting

Problem	Cause	Solution
Pressure drops in the tank.	Air leaks at connections.	Let the compressor build pressure in the tank, to the maximum pressure if possible. Brush soapy water on air connections and look carefully for air bubbles. Tighten leaky connections. If the problem persists, contact the seller for further advice.
The unloader valve leaks when the compressor is idle.	Unloader valve seal is defective.	Let the air in the air tank flow out until all the pressure is released. Then remove the unloader valve plug and clean the valve seal. If necessary, replace the seal and then reinstall all components.
The compressor stopped and does not stop.	The thermal protector turned on because the motor is overheating.	Check that the main voltage corresponds to the air compressor specifications. An extension cord that is too thin or too long can cause a voltage drop and cause the motor to overheat.  Excessive use (over 1-hour continuous use) can cause the motor to overheat.  Allow the motor to cool down.
	Motor windings are burned out.	Contact Promate Service for technical assistance.
The motor does not start and makes a humming noise.	Capacitor is burned out.	Replace starter capacitor.
The motor does not start or starts slowly.	Low voltage supply to the motor.	Check that the main voltage corresponds to the air compressor specifications.  An extension cord that is too thin or too long can cause a voltage drop... Use heavy duty extension cords.  Ensure that the air compressor is plugged into a fully functional power outlet.
The compressor is noisy with metallic clangs.	Compressor head gasket or reed valve is damaged.	Stop the compressor and contact the dealer.
The compressor does not reach the maximum pressure.	Compressor head gasket or reed valve is damaged.	Stop the compressor and contact the dealer.
The compressor doesn't seem to provide as much air as it did when new and/or the compressor cuts off within a much shorter time period.	The pressure switch needs adjusting.	Stop the compressor and contact the dealer.
	The tank is full of water due to condensation.	Open the drain valve and release the water from the tank.
The motor pump unit does not stop when the tank pressure reaches the maximum working pressure (125 PSI)	Pressure switch is defective or needs adjusting.	Stop the compressor immediately and contact Customer Support.



## 7. SERVICE INFORMATION

### HOW TO ORDER REPLACEMENT PARTS

Even quality-built equipment such as the generator you have purchased will need occasional replacement parts to maintain its good condition over the years.

To order replacement parts and consumable parts, please contact Promate Service (details below) and be ready with the following information:

1. Model No., Serial No. and all specifications that are shown on the Model No./Serial No. plate.
2. Part number or numbers as shown in the Parts List section.
3. A brief description of the trouble with the generator.

### LIMITED WARRANTY

Warranty Coverage: Powertech Asia Pacific Inc., (the Company) warrants to the original retail customer that it will repair or replace, free of charge, any parts found by the Company or its authorized service representative to be defective in material or workmanship. This warranty covers the cost of replacement parts and labor for defects in material or workmanship.

#### Not Covered:

- Shipping/Handling charges for sending the product to the Company or its authorized service representative for warranty service. Shipping/Handling repaired or replaced products back to the customer; these charges must be borne by the customer.
- If a separate operator's manual and engine warranty from the engine manufacturer is included with this product, only that warranty will apply to the engine.
- Damage caused by abuse, accident, the effects of corrosion, erosion and normal wear and tear.

- Warranty is void if the customer fails to install, maintain and operate the product in accordance with the instructions and recommendations of the Company set forth in the owner's manual, or if the product is used as rental equipment.
- The Company will not pay for repairs or adjustments to the product, or for any costs of labor performed without the Company's prior authorization.
- Consumable parts such as battery, spark plugs, and air cleaner.

Warranty Period: One (1) year from the date of purchase on products used solely for consumer applications; if a product is used for business or commercial applications,

the warranty period will be limited to ninety (90) days from the date of purchase.

For warranty service, the customer must provide dated proof of purchase and must notify the Company within the warranty period.

EXCLUSIONS AND LIMITATIONS: THE COMPANY MAKES NO OTHER WARRANTY OF ANY KIND, EXPRESS OR IMPLIED. IMPLIED WARRANTIES, INCLUDING WARRANTIES OF MERCHANTABILITY AND OF FITNESS FOR A PARTICULAR PURPOSE, ARE HEREBY DISCLAIMED. THE WARRANTY SERVICE DESCRIBED ABOVE IS THE EXCLUSIVE REMEDY UNDER THIS WARRANTY; LIABILITY FOR INCIDENTAL AND CONSEQUENTIAL DAMAGES IS EXCLUDED TO THE EXTENT

PERMITTED BY LAW.

This warranty gives you specific legal rights, and you may also have other rights which vary from state to state. Some states do not allow a disclaimer of implied warranties or the exclusion or limitation of incidental and consequential damages, so the above disclaimers and exclusions may not apply to you.



**CONTACT THE POWERTECH Asia Pacific Inc.,**  
PRODUCT SERVICE DEPARTMENT AT (02) 8 638 1569 | (+63) 9338373922  
service@powertechasiapacific.com www.facebook.com/PromateServicePH/



## Air Compressor Exploded View

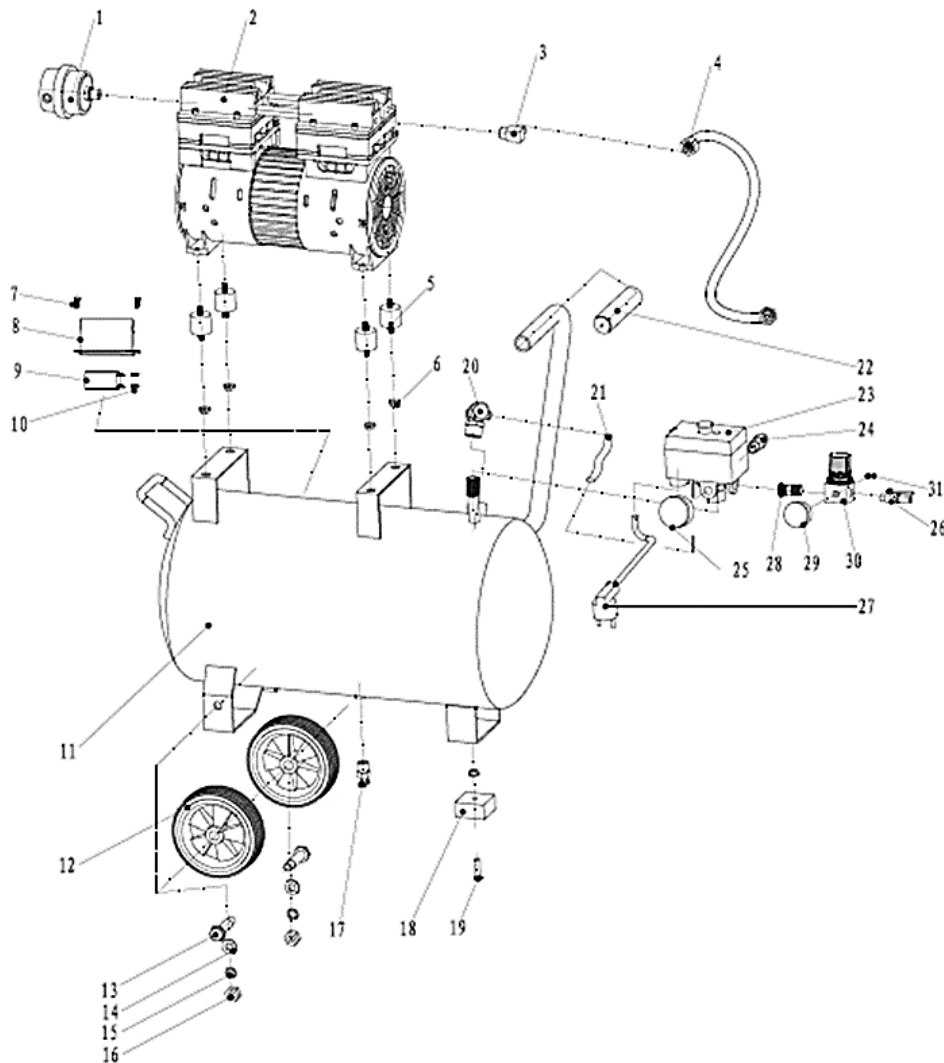

NO.	Description	Qty	NO.	Description	Qty
1	Air Filter Assembly	1	17	Drain Valve	1
2	Air Compressor Pump Head	1	18	Shock Strut	1
3	Elbow	1	19	Bolt	1
4	High Pressure Metal Hose	1	20	Check Valve Assembly	1
5	Shock Strut	4	21	Exhaust Hose	1
6	Nut	5	22	Rubber-covered Hand Rim	1
7	Bolt	2	23	Switch	1
8	Capacitor Box	1	24	Safety Valve	1
9	Capacitor	1	25	50 High Pressure Gauge	1
10	Groove	2	26	Connector	1
11	Air Tank	1	27	Wire Assembly	1
12	Wheel	2	28	Connector	1
13	Bolt	2	29	40 High Pressure Gauge	1
14	Flat Washer	2	30	Regulator	1
15	Spring Washer	2	31	Plug	1
16	Nut	2			